

# FORGINGS



2612 Howard Street  
Louisville, Kentucky 40211  
USA

Phone: 502-774-6011  
Fax: 502-774-6300

Website: [www.sypris.com/TubeTurns](http://www.sypris.com/TubeTurns)  
For general inquiry please contact us: [LouisvilleTTWeb@sypris.com](mailto:LouisvilleTTWeb@sypris.com)

The information contained herein is based on data and information developed in the Laboratories of Sypris Technologies ("Seller"), but is presented without guarantee or warranty, and the seller disclaims any liability incurred from the use thereof. Nothing contained herein is to be construed as a recommendation for any use, including without limitation, any use in a commercial process not controlled by seller, nor for a use which is in violation of any existing patent, foreign or domestic or of applicable laws and regulations.



# ANCHOR FORGINGS

The ANCHOR FORGING is designed for immobilization of high pressure pipe lines. Normally, it is a relatively simple matter to compensate for expansive movement of pipe caused by temperature changes and internal pressure. The designer calculates the amount of expansion (or contraction) to be expected and then provides expansion elements such as loops, offsets, bends, etc., to give the line sufficient flexibility to absorb the stresses that are created. In conjunction with this, there must be a suitable number of anchors installed to ensure proper functioning of the expansion element. But at pipeline river crossings, compressor stations, meter and valve settings, etc., the problem is complicated by the magnitude of the end forces resulting from the use of large diameter pipe (a 30" O.D. x .500 wall pipe subjected to a 90° F temperature change and an operating pressure of 1000 psi will develop an end thrust of over 1,000,000 pounds, for instance) and the difficulty of providing adequate anchorage. Anchor forgings can address these problems.

## THE WELDING NECK ANCHOR FORGINGS

The welding Neck Anchor Forging overcomes the difficulties normally encountered in anchoring, for the pipe is always held immobile, there are no unnecessary stress raisers created because of filled welds on the O.D. of the pipe and the possibilities of underbead cracking are minimized since the assembly is butt-welded.

The Anchor forging looks like a double-hubbed welding neck flange with no bolts. The hubs are of the straight-taper that permits the attachment of flange material to high yield line pipe without the use of transition pieces. For economy, the anchor forging is normally furnished in A105 with a minimum yield of 42,000 psi and additional thickness is provided at the welding end to compensate for high yield pipe. When required, the anchor forging can be furnished in higher yield materials such as A694 and A707. The hubs are butt-welded to the pipe at a point where the line is to be held immobile and the entire assembly is embedded in steel-reinforced concrete. Thus, the forces that result from thermal changes and pressure loads in the pipe are transmitted to an external anchoring structure.

## CUSTOM DESIGN

Anchor forgings are custom designed to provide the most economical dimensions for each special application. Stress calculations are performed as outlined in ASME Section VIII, Division I, Appendix 2. Shown in Figure 1, as an example, are typical dimensions for an anchor forging designed to match a 24" O.D. x .500 wall, API 5LX60 pipe, Type "B" construction, 1480 psi with a temperature differential of 90°F and a maximum concrete bearing stress of 1500 ppi.

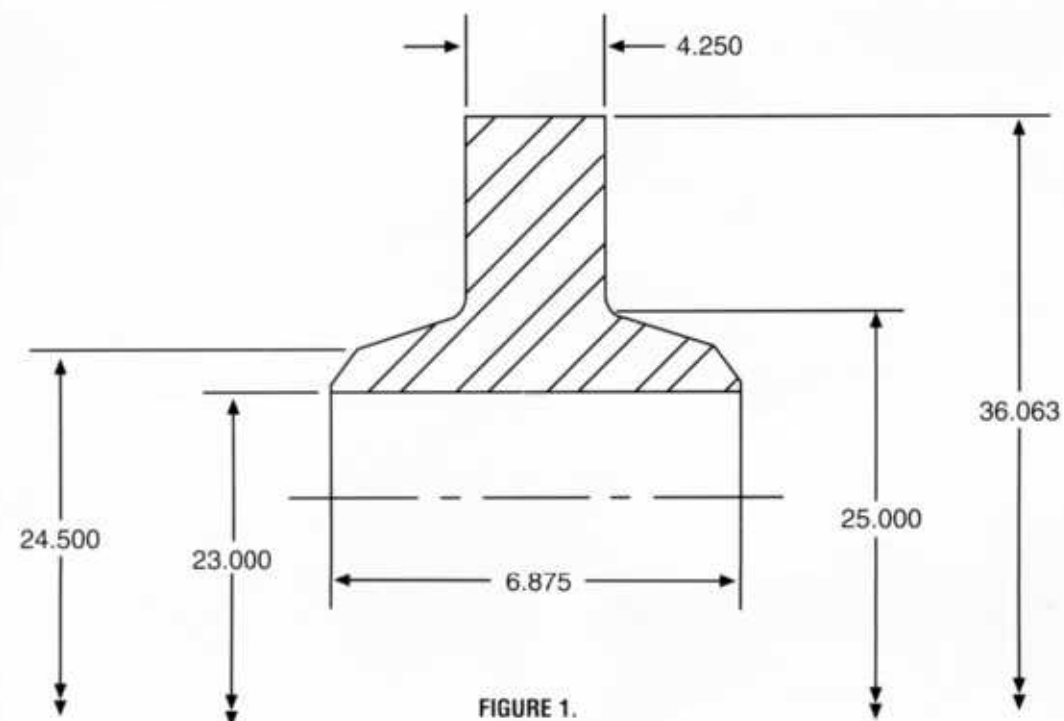

FIGURE 1.

## SPECIAL REQUIREMENTS

Sypris Technologies is fully qualified in-house to provide Magnetic Particle, Ultrasonic and Liquid Penetrant Examinations of these forgings to meet the most stringent specification requirements.

## INFORMATION NEEDED WITH INQUIRIES

In order to reply promptly to inquiries and to propose the most economical design for specific/service conditions, the following information is needed:

1. Matching pipe O.D., wall thickness, minimum yield, material spec.
2. Design Pressure
3. Temperature Differential
4. Design Code (ASME, B31.4 or B31.8)
5. Design factor (if applicable)
6. Design concrete bearing stress (if not specified, 1500 psi will be used)
7. Special requirements (NDE, Charpy tests, unusual loads, etc.)